

Ram Island Yacht Club, Inc

Station: Front Street
Noank, Connecticut 06340

Entry Form for the Around Fishers Island Race

Name of Yacht

Identification number on mainsail & headsails.....

If your HULL was built as a class give the name of the class, (Farr 40, TP 52, Catalina 22 Etc.)

Color of Hull

PHRF-LIS Rating.....(Please Note if Cruising Canvas) Attach a copy of PHRF certificate.

Number in crew.....

If you do not have a valid PHRF-LIS Rating please complete the diagram below. Not required for Ensigns.

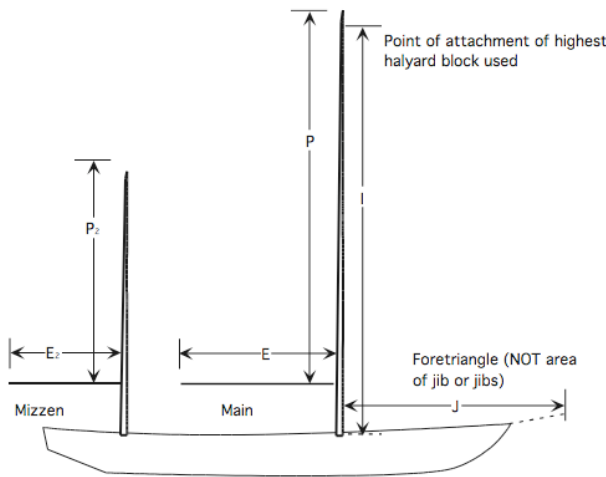

Shortest distance between extreme after end of clew cringle and forward side of luff for largest headsail to be carried in the race (LP)

Length of spinnaker pole.....

Maximum girth of spinnaker (G).....

Beam

Draft

Displacement.....

Length: Overall Water Line Rig

Propeller (feathering, folding, or solid)

Propeller (two blade or three blade)..... Prop. Dia..... Prop Blade Width

Rudder attached to ballast keel Yes No Fin Keel Yes No Centerboard Yes No

RESPOSIBILITY AND WAIVER/RELEASE OF LIABILITY – I understand that the safety of my yacht and her crew, and the decision whether or not to continue to race, are my responsibility and not that of the Ram Island Yacht Club. I must evaluate the safe condition of the yacht, weather and sea conditions, safety equipment on board and conditions governing the race, among other things, in making that decision. I know One Design Entries must adhere to all locally sanctioned rules for that class. In consideration of the clubs acceptance of this entry, I for myself and my heirs, legal representatives, successors and assigns hereby waive any and all claims which I and any of them may at any time have against the Club, its officers, members of the board of trustees, chairmen and members of Club Committees, other Club members, and any of their employees and agents arising out of my participation and the participation of my yacht in this event.

My signature below indicates my full understanding of, and my agreement to fulfill, the responsibilities listed above.

Captain's Signature.....

Owner's Name Yacht Club.....
(please Print)

Owners Address
(please Print)

Phone.....

Send entries to: Wendy Schnur, 83 Bayview Avenue, Mystic CT 06355